

A close-up photograph of two hands shaking. The hand on the left is wearing a camouflage military uniform sleeve. The hand on the right is wearing a red and white plaid shirt sleeve. The background is a solid red color.

UKRAINIAN
VETERANS
FOUNDATION

EMPOWERING THE STRONGEST

YEAR IN NUMBERS

2022

13,5 mil UAH - raised

57,4 mil UAH grant contracts for veterans/NGOs

over 5000 - calls on the hotline

Over 140 - projects supported

46 - persons in the team

11 000 - facebook

14 000 - twitter



UKRAINIAN
VETERANS
FOUNDATION

YEAR IN NUMBERS

2

ЛЮТИЙ

Реєстрація

БЕРЕЗЕНЬ

Чатбот

КВІТЕНЬ

Радіопрограма "Хвиля перемоги"

2

ТРАВЕНЬ

Офіційний сайт

ЧЕРВЕНЬ

Проект мікрофінансування "20 000"

ЛИПЕНЬ

Гаряча лінія кризової підтримки

0

СЕРПЕНЬ

Проект ветеранської пісні #Артфронт

Аналітичне дослідження "Портрет ветерана"

Міжнародний форум "Там, де ми - там Україна"

ВЕРЕСЕНЬ

запуск конкурсних програм #варто,
#варто+ГО, #варто 2.0

2

ЖОВТЕНЬ



UKRAINIAN
VETERANS
FOUNDATION

STRATEGIC GOALS 2022

| | Operational goal | Implementation indicator | PLAN | FACT | PERCENTAGE % |
|------------------|--|---|------------|------------|--------------|
| Strategic goal 1 | Creation and development of the institutional and financial capacity of the Ukrainian Veterans Fund | | | | |
| OG 1.1 | Creating a team and forming a staff | Staff turnover is no more than 30% | 30% | 18% | |
| OG 1.2 | Ensuring the functioning of processes and procedures in accordance with current legislation | The document management system, personnel service, financial and legal services have been established, and a project management system has been created | | | |
| OG 1.3 | A working system of planned fundraising has been created | Additional extra-budgetary financing was involved | 40 000 000 | 13 500 000 | 34 |
| Strategic goal 2 | Financing of veteran entrepreneurship | | | | |
| OG 2.1 | A project management system has been created, the collection of applications has been launched | The number of projects submitted for financial support | 25 | 144 | 576 |
| OG 2.2 | A system of expertise on veteran entrepreneurship has been created | The number of experts engaged | 15 | 6 | 40 |
| OG 2.3 | Relevant applications were selected, projects were financed, and reports were received | The number of projects implemented with the financial support of the Ukrainian Veterans Fund | 12 | 52 | 433 |
| Strategic goal 3 | Creating a barrier-free environment for all categories of citizens defined by this Strategy and the Law of Ukraine | | | | |
| OG 3.1 | A project management system has been created, the collection of applications has been launched | The number of projects submitted for financial support | 15 | 31 | 207 |
| OG 3.2 | A system of expertise on barrier-free issues has been created | The number of experts engaged | 10 | 3 | 30 |
| OG 3.3 | Relevant applications were selected, projects were financed, and reports were received | The number of projects implemented with the financial support of the Ukrainian Veterans Fund | 5 | 6 | 120 |
| Strategic goal 4 | Funding of projects aimed at support and reintegration of persons identified by this Strategy who find themselves in difficult life circumstances | | | | |
| OG 4.1 | A project management system has been created, and the collection of applications has been launched | The number of projects submitted for financial | 5 | 8 | 160 |
| OG 4.2 | A system of expertise on issues of reintegration into civilian life has been created | The number of experts engaged | 5 | 3 | 60 |
| OG 4.3 | Relevant applications were selected, projects were financed, and reports were received | The number of projects implemented with the financial support of the Ukrainian Veterans Fund | 2 | 2 | 100 |
| OVERALL % | | | | | 176 |



BUDGET PROCESSES

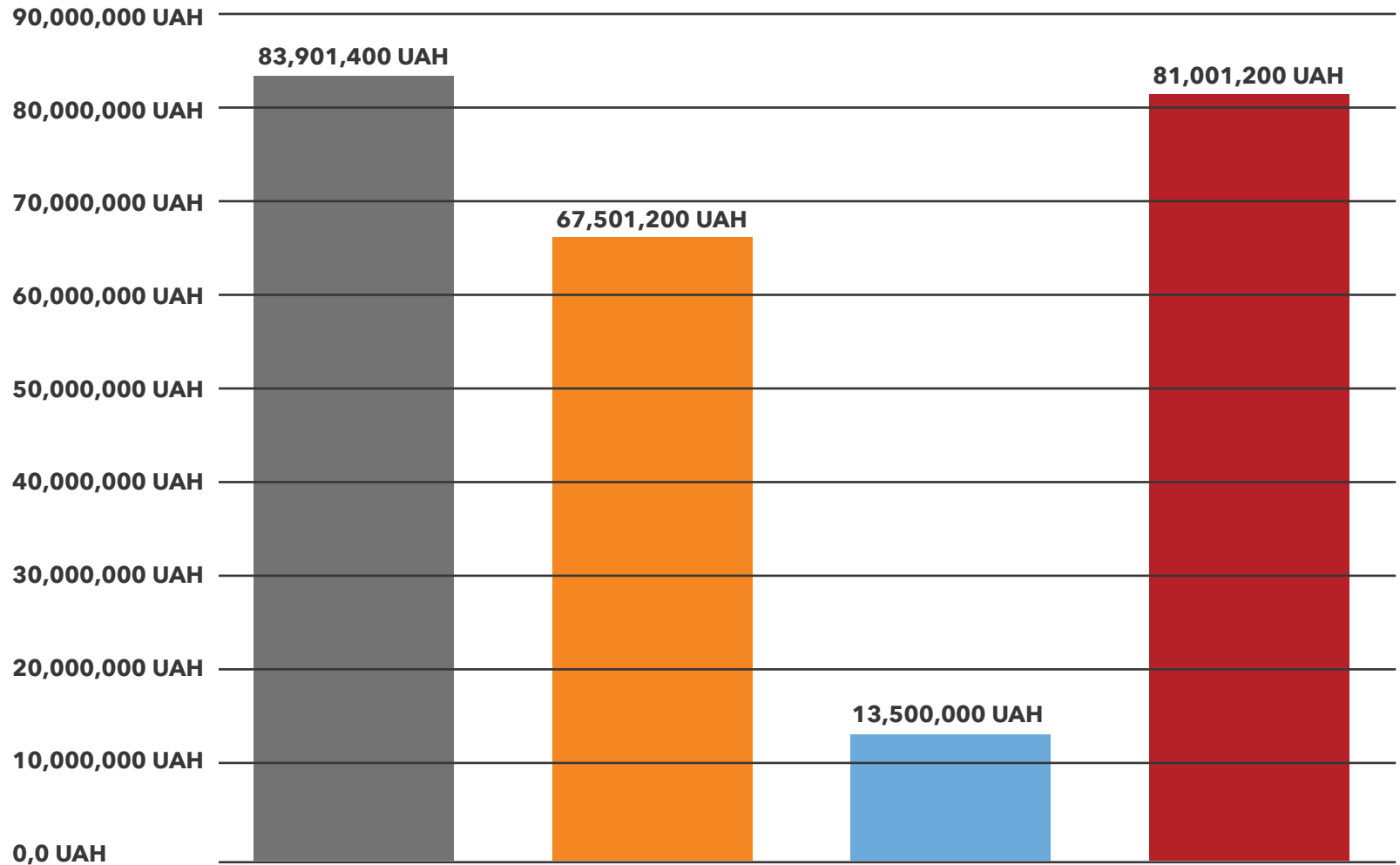

PROJECTS

Вірте в ППО!

А КОЛИ ТРИВОЖНО - ТЕЛЕФОНУЙТЕ
НА ГАРЯЧУ ЛІНІЮ
0 800 33 20 29

URRF IREX

МІНІСТЕРСТВО
У СПРАВАХ
ВETERANІВ
УКРАЇНИ

- **Over 5000 calls**
- **Online groups**
- **Legal support - pending**

МІНІСТЕРСТВО
У СПРАВАХ
ВETERANІВ
УКРАЇНИ

**20 ТИСЯЧ
ВETERАНСЬКОМУ
БІЗНЕСУ**

Icons: battery, laptop, coffee cup, paintbrush, gear

- **Over 200 submissions**
- **80 submissions supported**
- **1,6 mio UAH**



PROGRAMS (SEPT-DEC 2022)

ОГОЛОШЕНО
ПЕРЕМОЖЦІВ КОНКУРСУ
#ВАРТО



ОГОЛОШУЄМО
ПЕРЕМОЖЦІВ
#ВАРТО+ГО

Ветеран
Олексій
Бешуля

виграв конкурс #ВАРТО на розвиток свого видавництва "Пропала Грамота"



Ветеран
Олександр
Рубан

виграв конкурс #ВАРТО на розвиток шелтеру для переселенців у селі Кароліно-Бугаз



Ветеранка
Вікторія
Ткач

Виграла конкурс #ВАРТО на зростання свого виробництва "Slice&dry"



Ветеранка
Катерина
Приймак

Виграла конкурс #ВАРТО на виробництво військового одягу



■ VARTO ■ VARTO NGO ■ VARTO 2.0

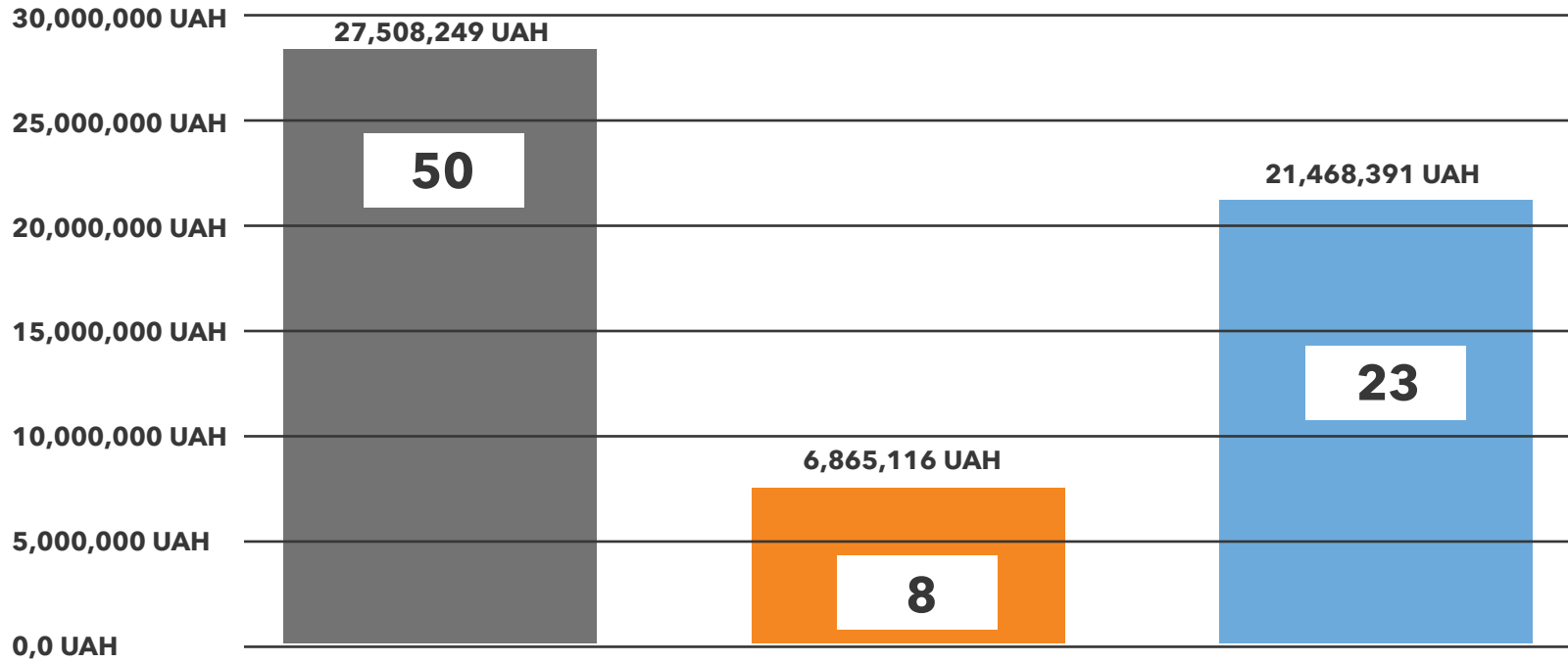

PROGRAMS BPMN

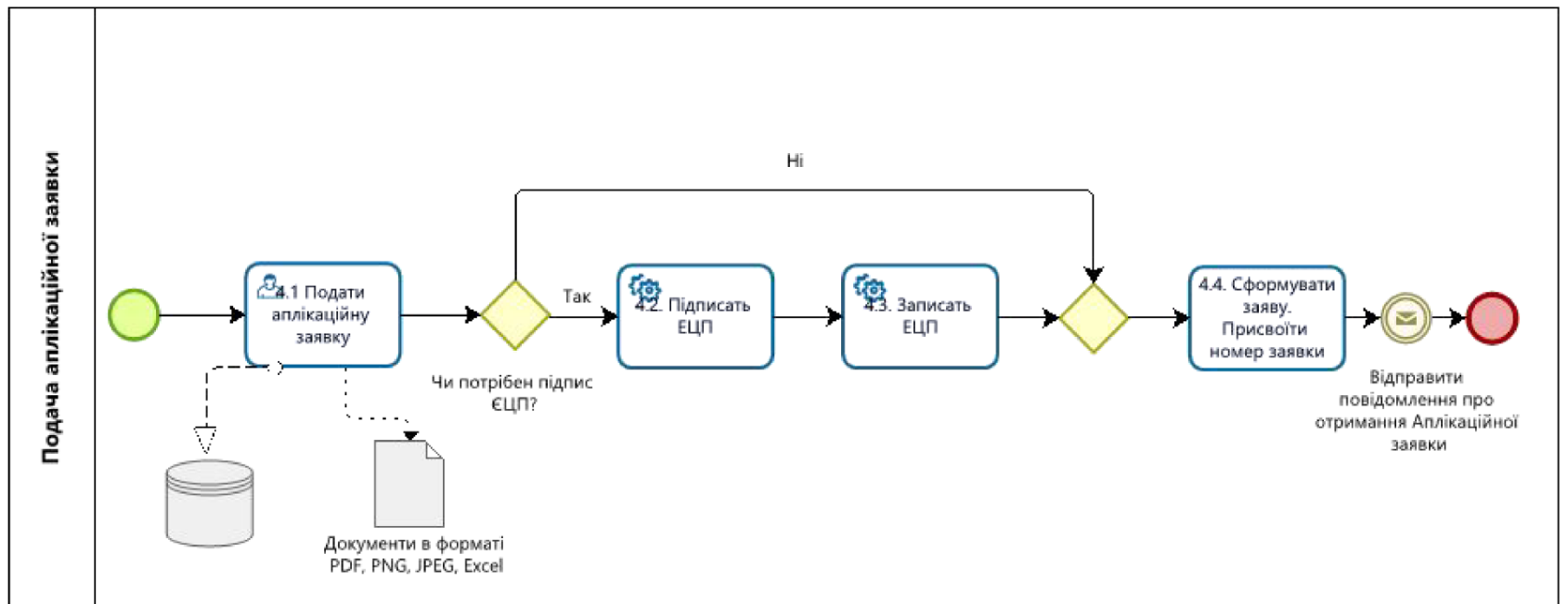

UKRAINIAN
VETERANS
FOUNDATION

PROGRAMS BPMN

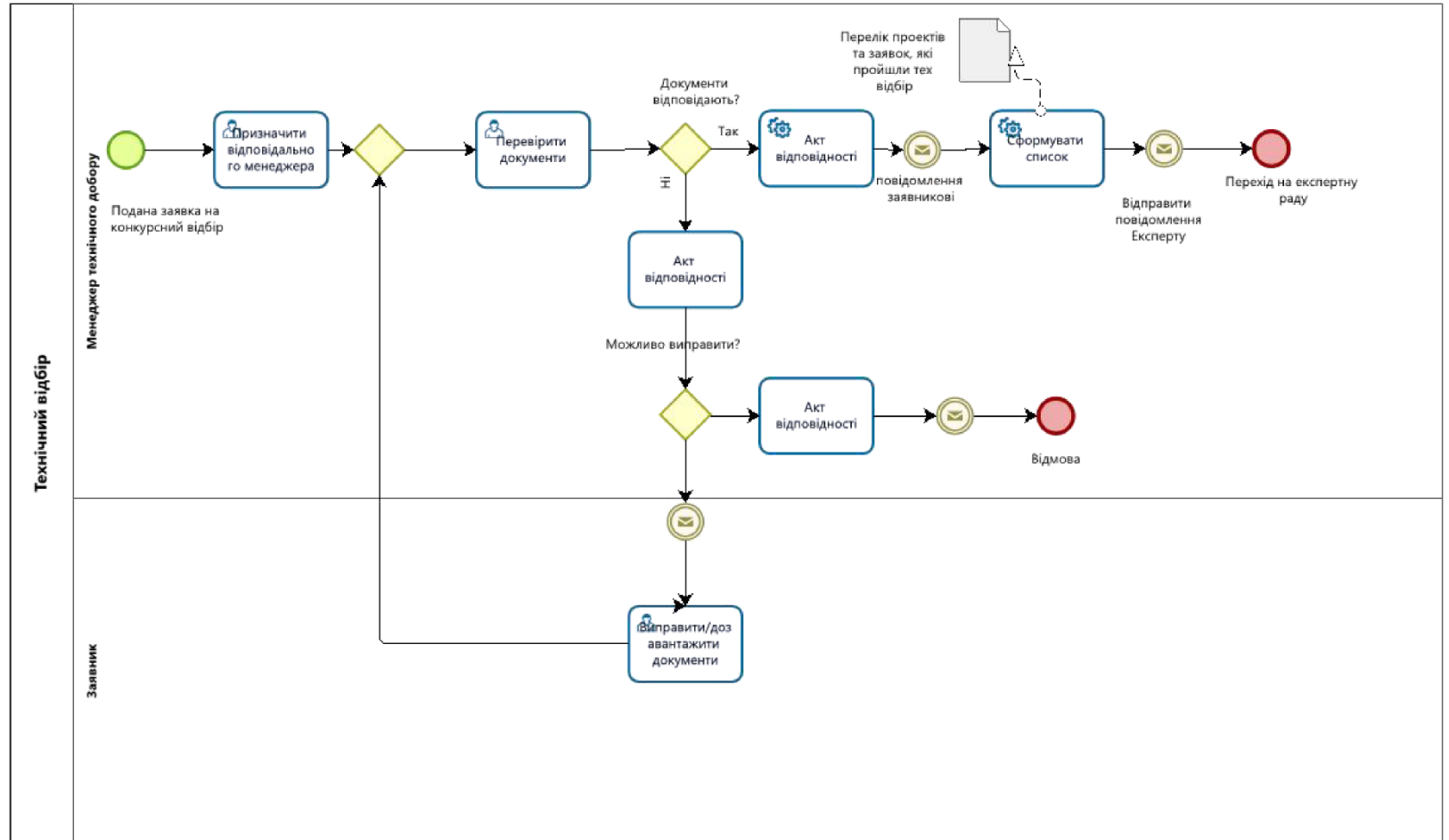

PROGRAMS BPMN

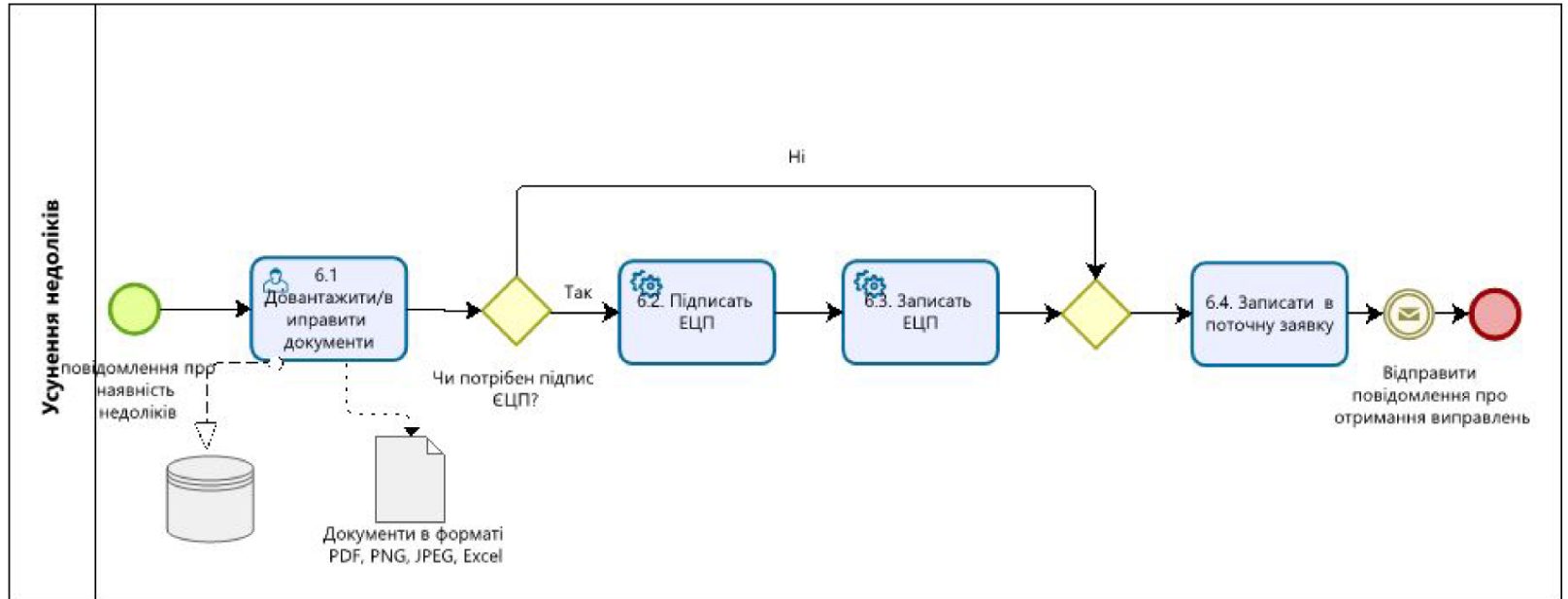

PROGRAMS BPMN

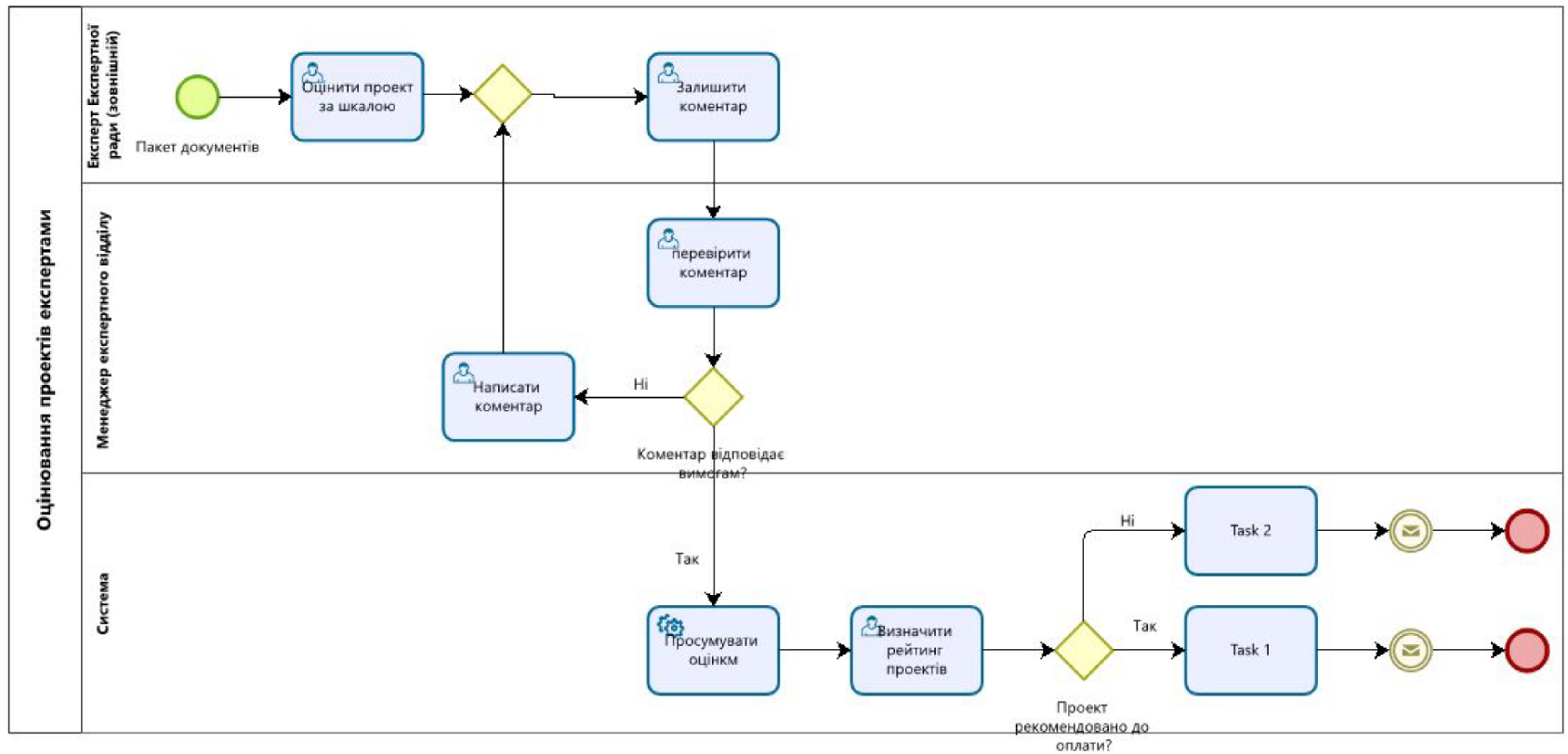

UKRAINIAN
VETERANS
FOUNDATION

PUBLICITY

Subscribers

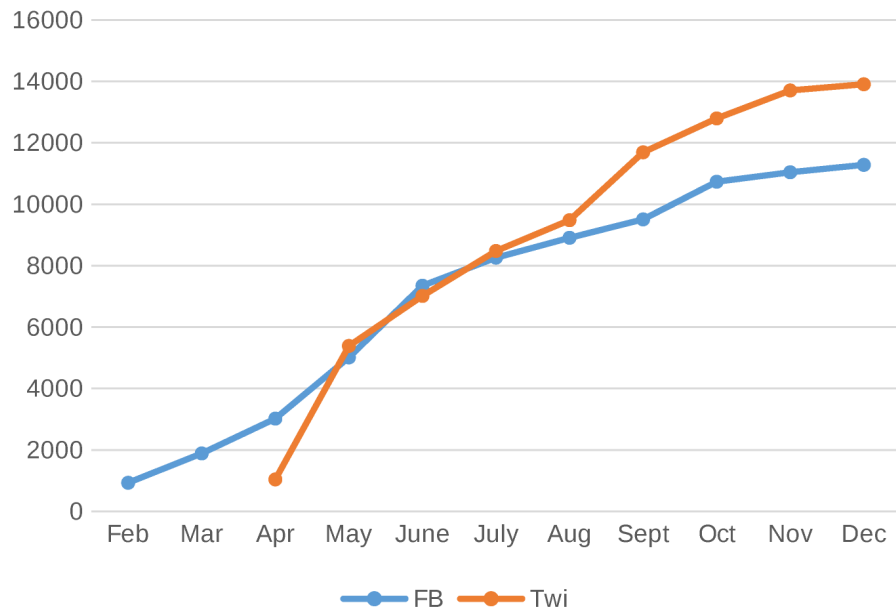

- **1,543 publications in media**
- **102 broadcasts on TV**
- **24 broadcasts on the radio**
- **88 broadcasts on Victory Wave**



Coverage

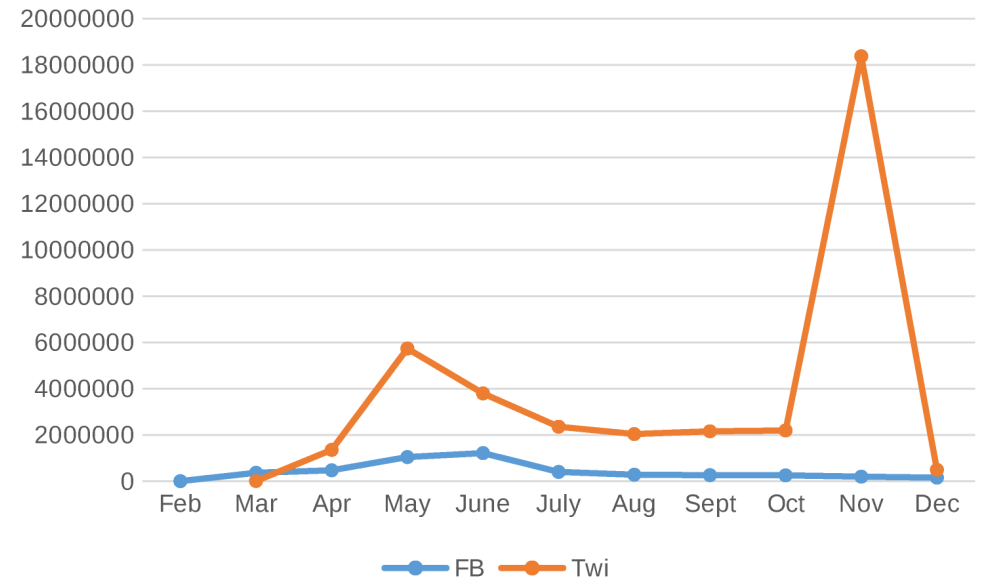

- **20 columns**
- **17 interviews**
- **20 publications in foreign media**

PROJECTS



Які емоції викликають в українців ветерани російсько-української війни?



PROJECTS





2023

STRATEGIC GOALS 2023

6. INTERNATIONAL
PARTNERSHIP

5. REGIONAL
DEVELOPMENT

4. PROJECTS

3. GRANTS FOR
VET BUSINESS

2. GRANTS
FOR NGOS

1. INSTITUTIONAL DEVELOPMENT



UKRAINIAN
VETERANS
FOUNDATION

FINANCIAL SUPPORT OF VETERANS BUSINESS

FINANCIAL SUPPORT NGOs

General program

National NGOs

Social support

Agro

Support for children

Manufacturing specialties

Local NGOs

Gender projects

Energy efficiency



BUDGET PROCESSES

GRANTS FOR VETERANS BUSINESSES

GRANTS FOR NGOS

INFORMATIONAL SUPPORT OF PROGRAMS

CLUB

VETERANS ENTERPREUNERSHIP
DEVELOPMENT

MENTORSHIP
VETERAN
TO VETERAN

20 000

SUPPORT HOTLINE

FUNDRAISING EVENTS

REGIONAL OFFICE

VETERANS FORUM

"RESPECT" PROJECT

INSTITUTIONAL DEVELOPMENT

UKRAINIAN
VETERANS
FOUNDATION



SWOT

| | Threats | Opportunities |
|------------|---|---|
| Political | <ul style="list-style-type: none"> •The spread of the aggression of the Russian Federation to other territories of Ukraine; •Uncertainty of state policy regarding funding; •Political games; •Reform of the CMU, changes in the composition of the Ministry •Creation of "pocket organizations" by authorities and local self-government bodies •Corruption of state authorities and local self-government; | <ul style="list-style-type: none"> •Political will at the state level to support veterans and their families •Support by international partners. |
| Economical | <ul style="list-style-type: none"> •Reduction in financing of the Fund's program due to the increase in the needs of the security and defense sector and the corresponding sequestration of the State Budget; •Further mobilization and increase in the number of combatants; •An increase in the number of deceased defenders and, accordingly, the number of families; •Global economic crisis | <ul style="list-style-type: none"> •Additional fundraising; •Strengthening international organizations funds through of financing by partners and organizations. |
| Social | <ul style="list-style-type: none"> •Manipulation of public opinion and creation of the image of a veteran as a dangerous criminal with PTSD etc, which can be created as an enemy IPSO and internally politically •Society's mistrust of state institutions; •Low awareness of the Fund's activities among target audiences. •Low level of skills and abilities in the target audience from the regions in the field of writing projects and submitting them for financing. | <ul style="list-style-type: none"> •Great public demand for support for defenders; •Supervisory Board •International organizations are highly interested in the needs of veterans. |



SWOT

| | Weaknesses | Opportunities |
|---------------|--|--|
| Political | <ul style="list-style-type: none"> •Weak institutional capacity of the Fund in the regions and internationally; | <ul style="list-style-type: none"> •Availability of support from international partners; •"Umbrella" of the Ministry of Veterans Affairs; •Support of the veteran community •Successful cases of program implementation by the Fund in 2022. |
| Economical | <ul style="list-style-type: none"> •Dependence on the state budget; | <ul style="list-style-type: none"> •Experience in successfully implementing projects for grant support; •The possibility of attracting additional funding for educational, advocacy and project activities of the Fund. |
| Social | <ul style="list-style-type: none"> •Staff turnover; | <ul style="list-style-type: none"> •Social capital of the director and other team members; •Trust from veterans •The presence of veterans, family members of veterans, and family members of fallen Defenders in the team; •High motivation for self-development in the team. |
| Technological | <ul style="list-style-type: none"> •Insufficient number of staff members of the Fund; •Energy terrorism of the aggressor's edge. | <ul style="list-style-type: none"> •Availability of expertise in working with veterans in a significant number of staff; •Understanding the context and needs of the target audience; •A developed network of communication and information exchange; •Positive experience in conducting sociological research among veterans; |



ONGOING 2023

3

ONLINE TRAINING COURSE WITH UCU

2

**DEVELOPMENT OF SPECIALISTS
IN PRODUCTION SPECIALTIES**

0

**SUPPORT AGRO AND ENERGY
EFFICIENCY PROJECTS**

2

REGULAR SOCIOLOGICAL SURVEYS

**EXPAND THE HOTLINE - ADDITION
OF LEGALCONSULTING**

OPENING OF THE REGIONAL OFFICE



**UKRAINIAN
VETERANS
FOUNDATION**

PARTNERS



RAZOM
Together we are Ukraine



**ТЕРИТОРІАЛЬНА
ОБОРОНА**
ГОТОВІ ДО СПРОТИВУ



IREX



**Ukrainian
Catholic
University**



LOBBY X
HUMAN CAPITAL PLATFORM



TEXTY.ORG.UA



Thanks!